

**Watertight expansion joint systems
Corrugated jointing system and sealing strips
for flat roofs and covered areas for sealing
against non-pressurized water**

Developed for large, multi-directional
movement in accordance with
DIN 18195

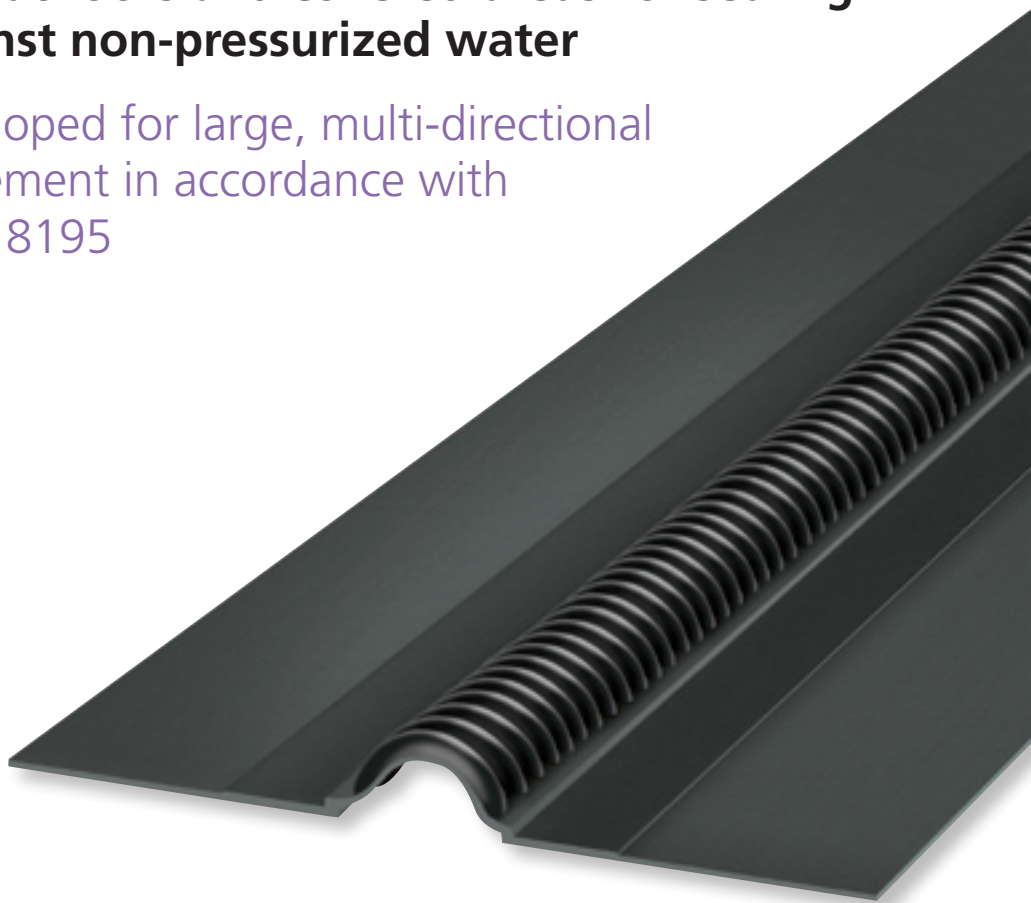
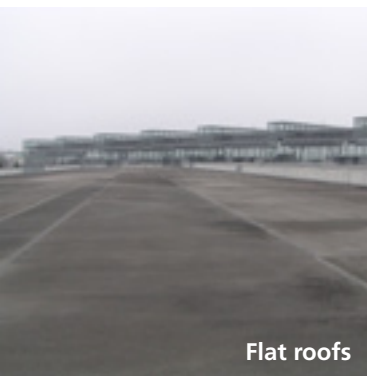

MIGUPREN is a comprehensive program of sealing strips for sealing of movement joints against non-pressurized water.

Just in Germany millions of square meter of flat roofs and covered areas exists and has to be sealed against non-pressurized water. The most sensitive area is the sealing of the expansion joints. Very often, the sealing of the floor- and wall-connections are the reason for leakages, which damage the structure of the building and occurs in high costs for redevelopment.

MIGUA provide with the sealing strips MP, FFD, WFB and DK four high sophisticated and well-experienced sealing strips, which meet all requirements of an effective, permanent and high quality sealing strip.

Content

	Page
Arrangement to scope of application / alphabet	3
Sealing strip MP 350, MP 420	4
System- and Material-Description	5
Installation Examples	6 - 8
Open areas	6
Below insulation	6 - 7
Below mastic Asphalt	7
Wall-connections	8
MIGUFLEX sealing strip FFD 40	9
Corrugated jointing system WFB 550	10
System- und Material-Description	11
Installation Examples	12 - 17
Flat roof – Version 1: Flange-construction	12
Flat roof – Version 2: Bonding	13
Flat roof – Wall-connections	14
Covered areas	15
Wall-connections	16
Loose- and fixed-flange-construction – Arrangement	17
Examples Terminations / Intersections	18 - 22
Installation examples	23
Example pictures of applications	24 - 25
Sealing strip DK 550	26
MIGUA – At a glance	27

Installation

Application and installation instructions will be provided on request. Please contact us. As an alternative you can download it from our website www.migua.com

Index to scope of applications

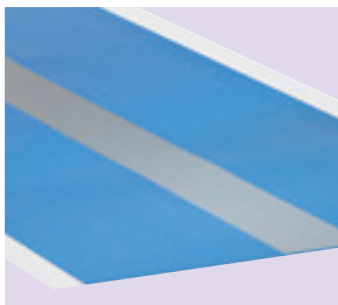

**Sealing strip
MP 350 / MP 420**

MIGUPREN MP is a new sealing strip with an extra flexible central part and two connection flanges with modified characteristics. It is used mainly on flat roofs, but also special areas of multi storey car parks, etc.

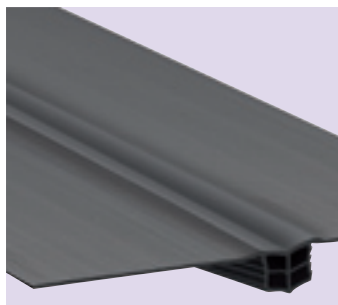

**MIGUFLEX
Sealing strip FFD 40**

MIGUFLEX sealing strip FFD 40 is a proven system for small joints. Butt welds can be done cost-effectively by welding on site. The strip is designed for sealing of flat roofs against non-pressurized water.

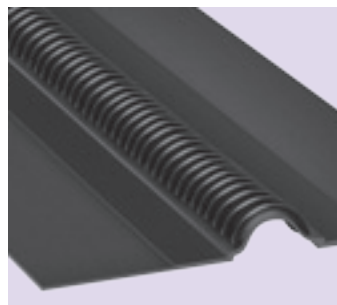

**Corrugated jointing
system WFB 550**

The special shape of the MIGUPREN corrugated jointing system WFB 550 (concertina principle) absorbs movements in all three dimensions. MIGUPREN corrugated jointing system WFB 550 has been used successfully for more than 20 years.

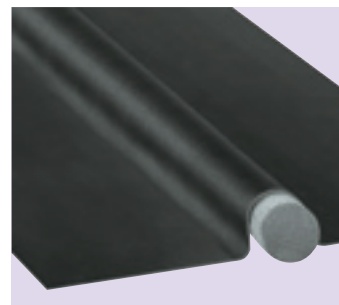

**Sealing strip
DK 550**

MIGUPREN sealing strip DK 550 offers a simple, but effective solution for sealing of flat roofs against non-pressurized water. The flexible, formed loop ensures a large horizontal and vertical movement in connection with different joint widths.

Series	Page
MP 350	4
MP 420	4

Series	Page
FFD 40	9

Series	Page
WFB 550	10

Series	Page
DK 550	26

Sealing strip for sealing against non-pressurized water (DIN 18195)

MP 350 / MP 420

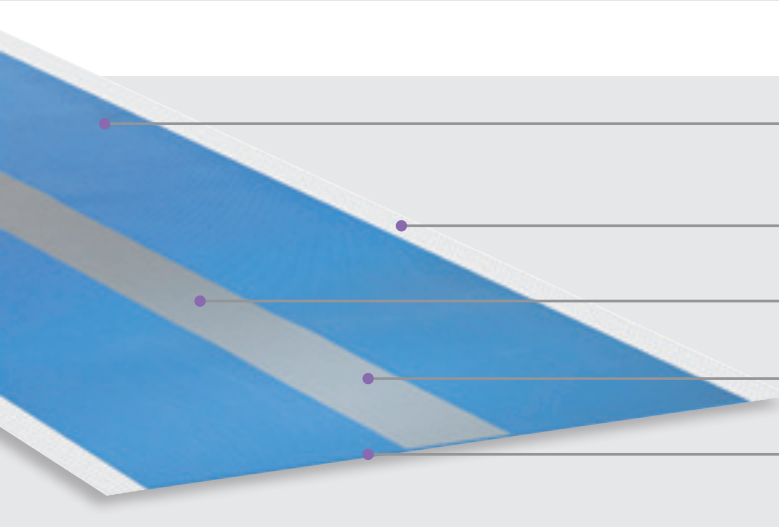

Perfect connection due to connection flanges on bitumen sheets as well as epoxy adhesive on concrete and metal (Official test certificate is available)

Protruding fabric for perfect connection in bitumen/epoxy

EPDM-Strip in elastic area for excellent ozone and UV-resistance

„Lotus“ Effect on top of elastic area prevents unintended bonding of bitumen

Sandwich-Installation possible without cost-effective sub-construction and without fixing

Profile	Joint width max. b_{f max} [mm]	Total width b_t [mm]	Movement capacity horizontal (x) [mm]	Movement capacity longitudinal (y) [mm]	Movement capacity vertical / settlement (z) [mm]
MP 350	50	350	± 30	± 15	± 22,5
MP 420	120	420	± 100	± 50	± 75

Standard colour: blue / grey (elastic area)
Production length: 40 m

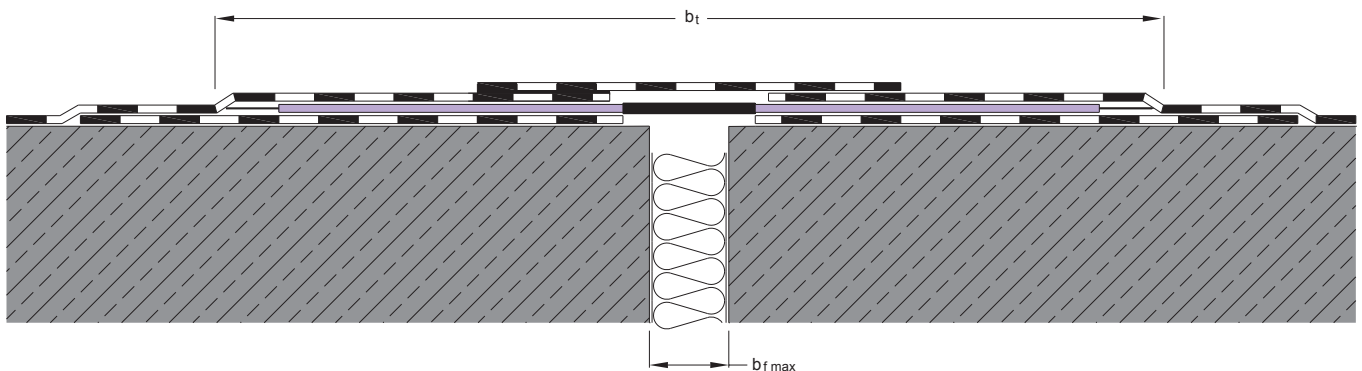

Sealing strip System- and Material-Description

MIGUPREN MP 350 / MP 420 is a novel design which consists of an elastic (central) area and connection flanges on either side for a long-term quality solution.

A specifically developed butyl-rubber-composition with a particularly elastic area ensures that the **three-dimensional movement** will only be absorbed and eliminated from the elastic area.

A strip of EPDM on top of the elastic area ensures excellent resistance to UV and ozone.

MIGUPREN MP sealing strip is **watertight and impervious to water vapour.**

The EPDM strip on the elastic area ensures **excellent resistance to UV and ozone.**

MIGUPREN MP sealing strip has a very good **thermal resistance:** Very good flexibility at low temperatures down to -40° and very good long-term heat resistance up to 90°C.

The material is characterized by excellent chemical resistance to alcohols and ketones, alkalis, dilute acids and salt solutions.

MIGUPREN MP sealing strip can be rolled up without deformation and can thus be **economically transported, stored and applied** in long lengths.

Simple processing on construction site:

The sealing strip, including intersections will be supplied to site in a prefabricated form.

Notes for Installation

The dry MP sealing strip have to be laid down completely without stretching it, to allow the expansion of the strip. The grey colored elastic area has to be visible on top. The connection flanges has to be bonded by means of hot bitumen to the first bituminous layer.

It is essential that a maximum of 1 m be prepared immediately and pressed into the hot bitumen by means of a broom or trowel.

The hot flame should not come in direct contact with the MP sealing strip.

For further information and detailed installation instructions please contact us. As an alternative you can download it from our website www.migua.com.

Fabrication of systems – vulcanization

From our experience, watertight movement joint constructions require completely prefabricated joint sealing systems. These systems cannot be fabricated economically and accurately on site, they can only be prefabricated in our factory. Therefore, it is safer and more economical to have complete joint sealing systems along with all necessary vertical and transverse intersections manufactured to detailed site measurement drawings in our factory.

Should the size of the application involve problems with transport and fabrication, the system has to be fabricated in several parts in our factory so that only butt vulcanizations will be necessary on site, which requires a portable vulcanization machine. Vulcanization on the site can be carried out by our fitters or by staff instructed by us. Our vulcanization machine can be lent on request if the fixing process is made according to our installation instructions (separately), the adhesion between the sealing strip and the bituminous roof layers is very good.

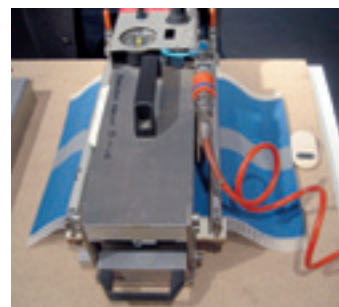

Installation Examples MP 350 / MP 420

The following illustrated installation examples have to be in accordance with their structural conditions individually reviewed and determined for each case.

They do not show the functional layers.
These have to be determined by the on-site situation.

N.B. these drawings are not to scale.

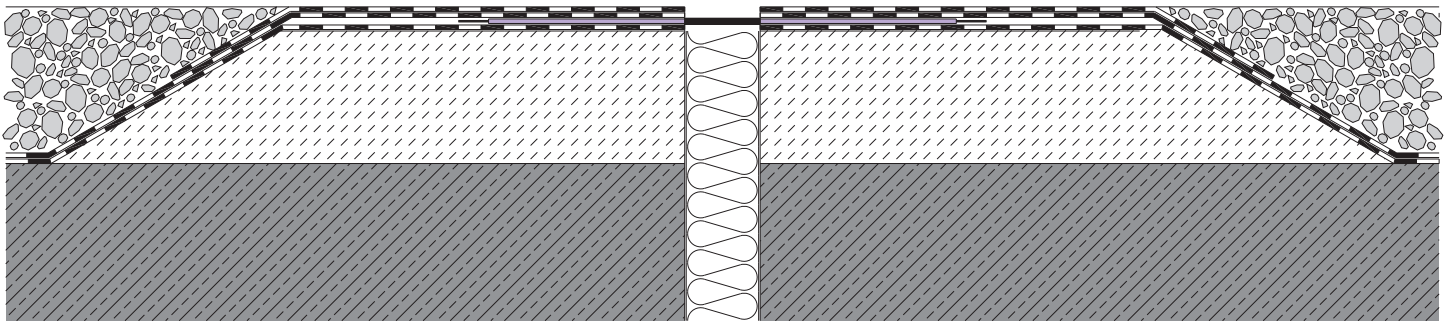

Horizontal application in open areas

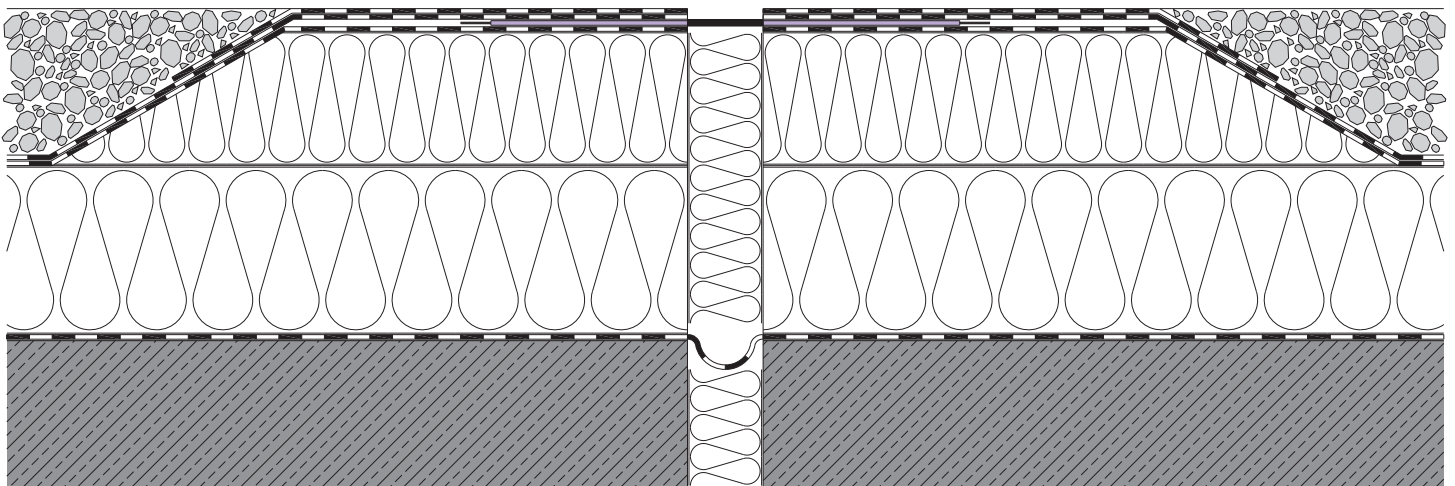

Horizontal application on top of insulation

Installation Examples MP 350 / MP 420

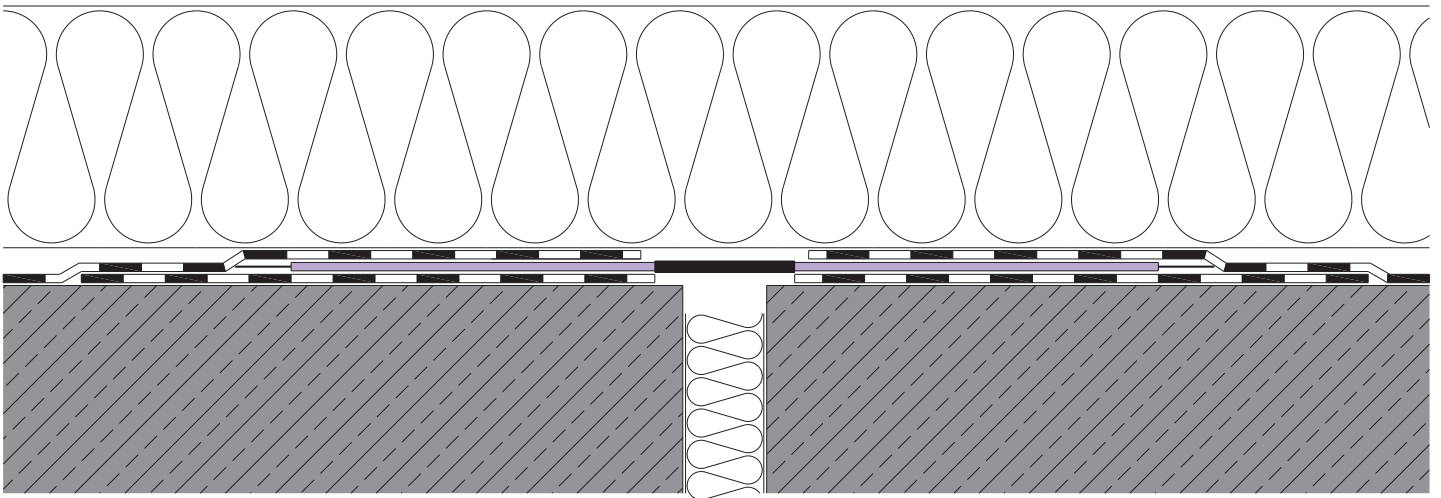

Horizontal application underneath insulation

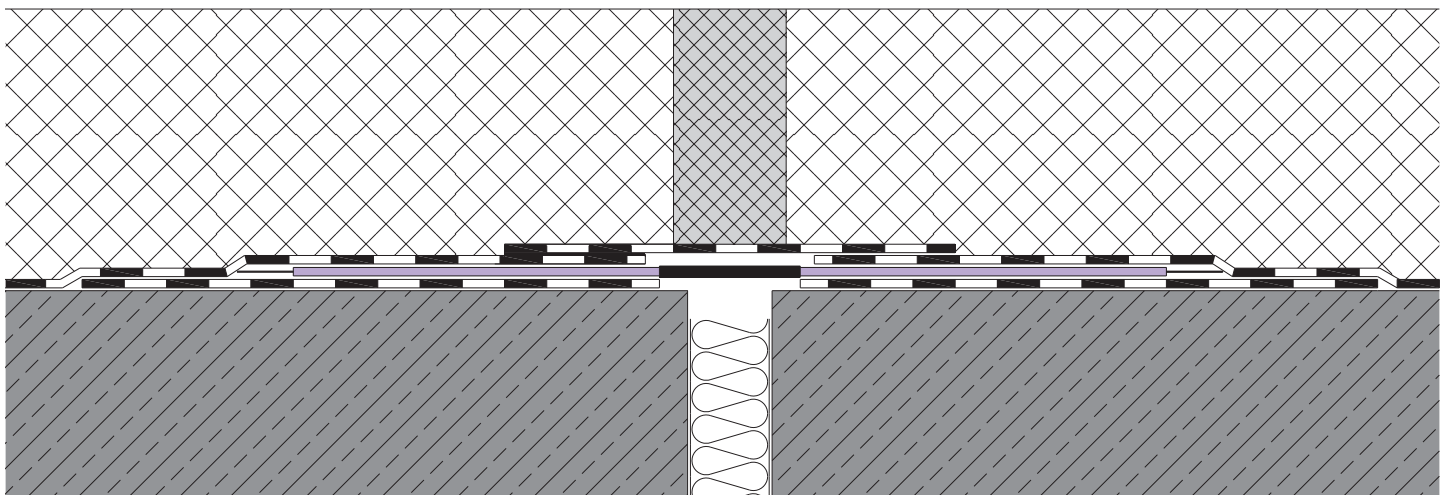

Application underneath mastic asphalt

Installation Examples

MP 350 / MP 420 Corner Versions

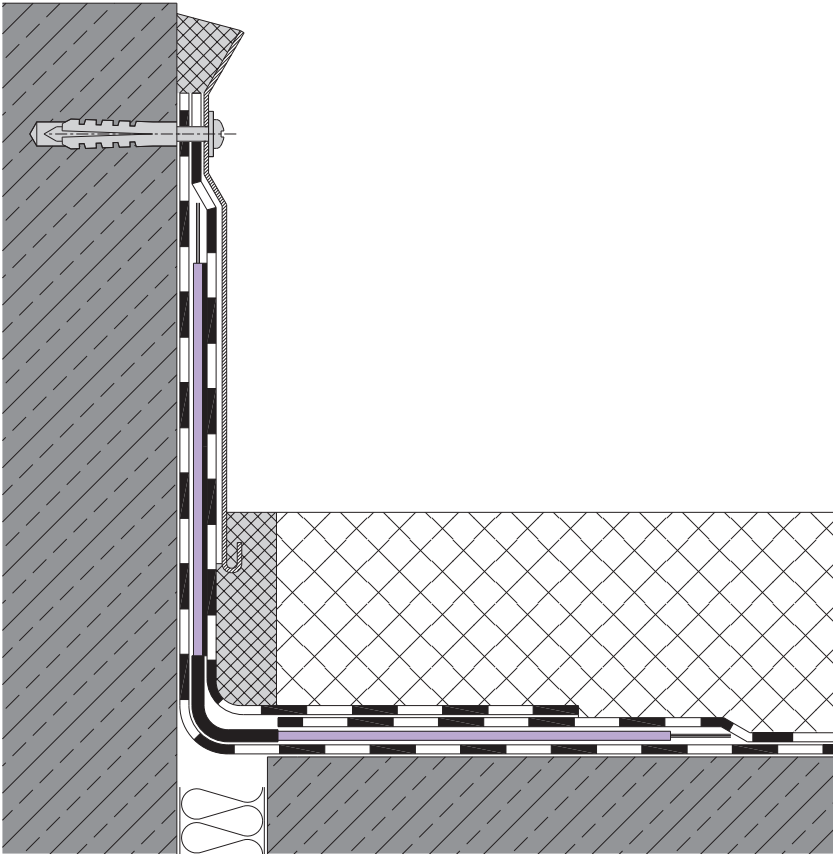

Corner Version underneath mastic asphalt

The illustrated vertical cover flashing and fixing flanges are not part of our supply and has to be supplied by others.

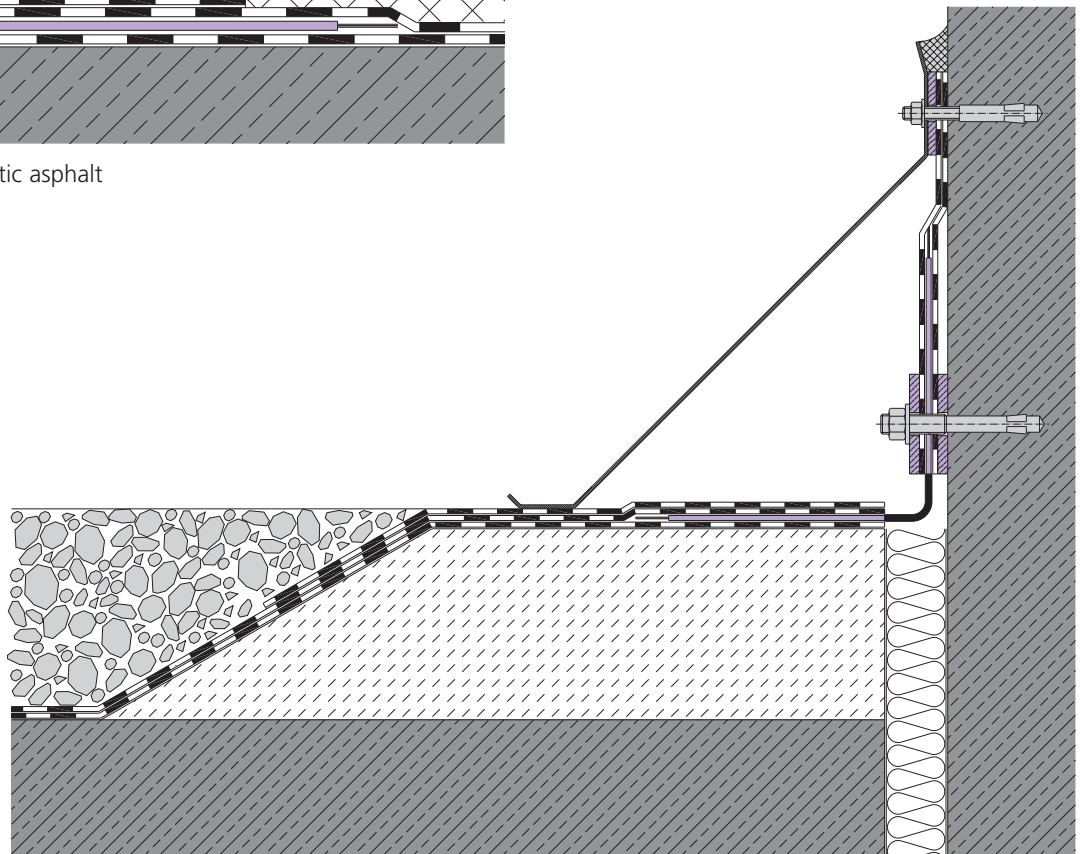

Corner Version with flange

MIGUFLEX sealing strip for sealing against non-pressurized water (DIN 18195)

FFD 40

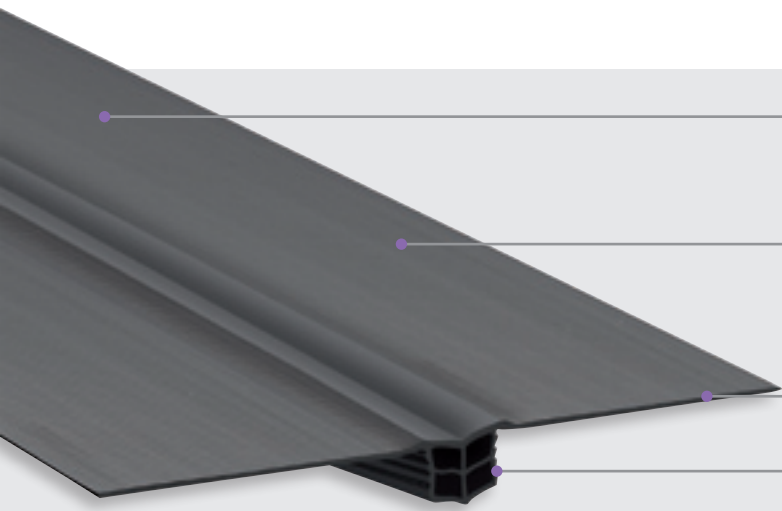

Connection flanges with striations on both sides for safe adhesion in hot bitumen between bituminous roof layers

150 mm wide connection flanges for optimum safety (as recommended for flat roofs)

Intersections and connections even for most complicated joint systems possible

3 sealing layers in movement area as protection against possible mechanical damage

Profile	Joint width min. bf min [mm]	Total width bt [mm]	Movement capacity Δbf [mm]
FFD 40	30	350	20 (± 10)

Material: MIGUFLEX
Standard colour: black
Production length: 20 m

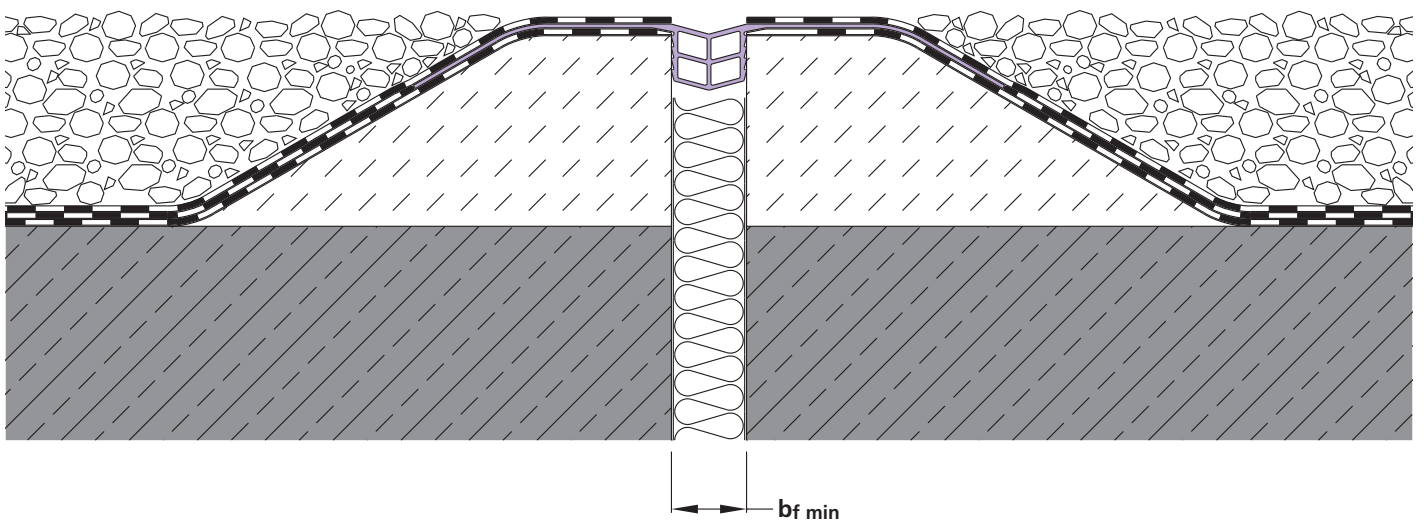

Corrugated jointing system for sealing against non-pressurized water (DIN 18195)

WFB 550

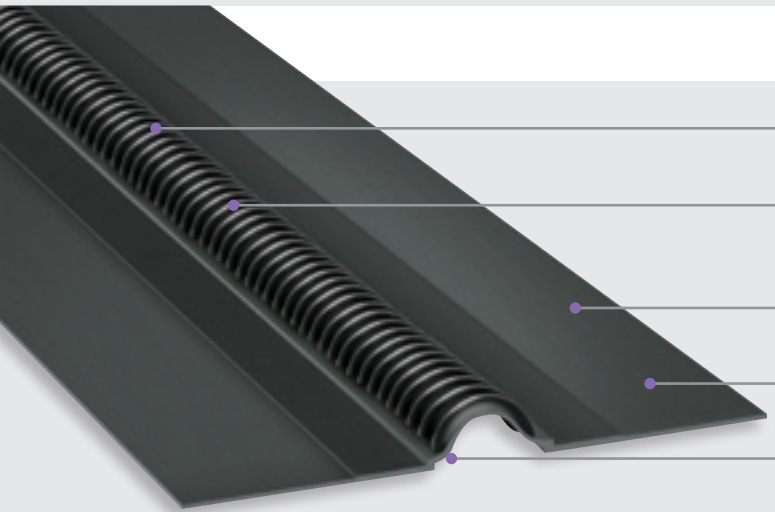

Corrugated jointing profile

absorbs movements in three directions

High stability due to special design of the corrugations

fitting of additional supports unnecessary

High quality material "Polychloroprene"

ensures highest thermal, chemical and mechanical resistance

Official test certificate for bonding

between bituminous sheets and corrugated jointing system available

Intersections and transitions

even for most complicated joint systems possible

Profile	Thickness Loop part [mm]	Total width b_t [mm]	Joint width max. b_{f max} [mm]	Movement capacity 3-dimensional [mm]
WFB 550	2,5	550	120	± 25

The movement capacity is valid for the simultaneous movement in all three directions.

Please ask for our separate installation instructions and our technical advice. We ensure a perfect fit by taking measurements on site (complete systems including all intersections, transitions and connections will be done in our factory).

Material: Polychloroprene, resistant to hot bitumen

Standard colour: black

Production length: depends on system

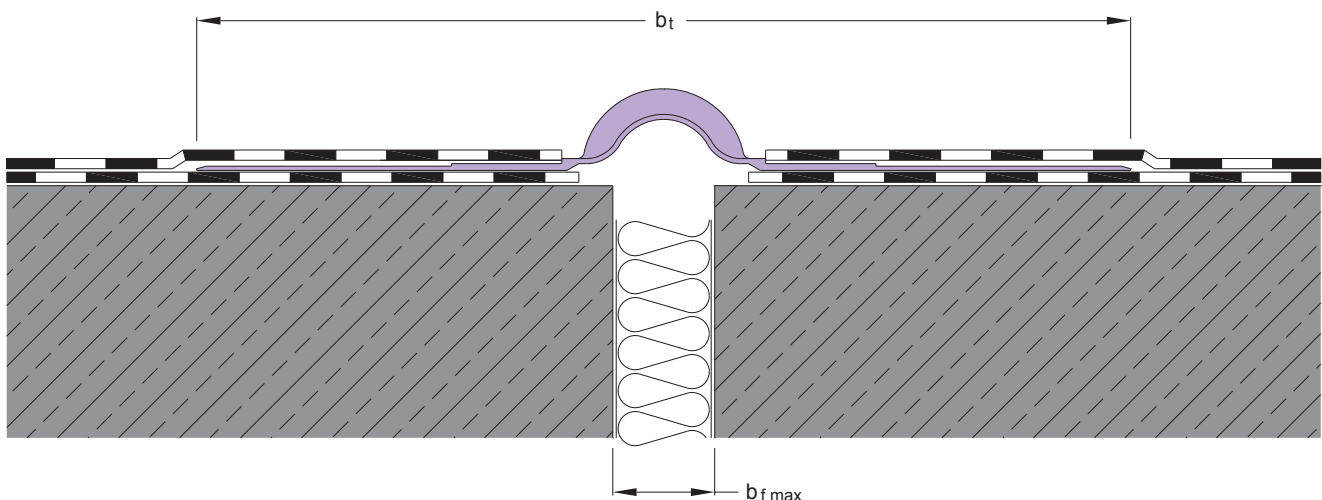

Corrugated jointing system System- and Material-Description

Material

For good reason, "Polychloroprene" synthetic rubber (Neoprene, Baypren) was chosen as the material for the MIGUPREN corrugated jointing system. The use of this material guarantees an almost constant elasticity over a **wide temperature range** (day, night, summer and winter). It has excellent ageing properties due to its resistance to ozone, light, UV-rays and to usual weather factors. MIGUPREN polychloroprene profiles are resistant to temperatures from -40°C up to short-time +180°C.

The material has **excellent resistance** to bitumen, oils, greases and other mineral oil products.

Polychloroprene is well known for its good abrasion resistance and its **resistance to mechanical stresses**. It shows only very slight permanent deformation (compression set) even after long-term loading. The compression set is approx. 5%.

MIGUPREN corrugated jointing profile can be rolled up without deformation and can thus be **economically transported, stored and applied in long lengths**.

PRÜFZEUGNIS
FMPA
STUTTGART

Official test certificate on the bond between the bituminous layers and the corrugated jointing system by means of break test is available and can be forwarded on request.

Production of Systems – Vulcanization

From our experience, watertight movement joint constructions require completely prefabricated joint sealing systems. These systems cannot be fabricated economically and accurately on site, they can only be prefabricated in our factory. Therefore, it is safer and more economical to have complete joint sealing systems along with all necessary vertical and transverse intersections manufactured to detailed site measurement drawings in our factory. Should the size of the application involve problems with transport and fabrication, the system has to be fabricated in several parts in our factory so that only butt vulcanizations will be necessary on site, which requires a portable vulcanization machine. Vulcanization on the site can be carried out by our fitters or by staff instructed by us. Our vulcanization machine can be lent on request. If the fixing process is made according to our installation instructions (separately), the adhesion between the corrugated jointing system and the bituminous roof layers is very good.

Three-dimensional movement

The special design of the MIGUPREN corrugated jointing system, which is based on the concertina principle, ensures that stresses, which occur as a result of longitudinal movements of the structure, are absorbed by the corrugations. As the material is not in a permanently stressed condition, the load transferred onto the roof layers is very low. The MIGUPREN corrugated jointing system not only absorbs longitudinal but also transverse and vertical movements in the corrugated area without high stresses being created in the sealing connection area.

The special design of the corrugations produces stability which makes the fitting of additional supports unnecessary.

The edges of the joint might displace themselves in one or all of the following directions:

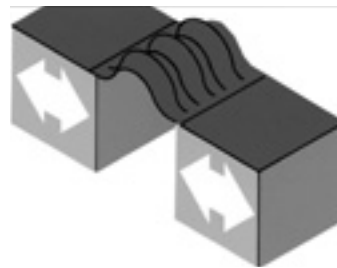

Transverse direction



Vertical direction



Lengthwise direction

Installation Examples WFB 550

Flat roofs – Method 1:

Flange connection DIN 18195 part 9

Fixing area on both sides of the looped part are in accordance with DIN 18195.

The illustrated installation detail (flanges – loose/flange-fixed) and the covers are not part of our supply.

They do not show the functional layers.
These have to be determined by the on-site situation.

N.B. these drawings are not to scale.

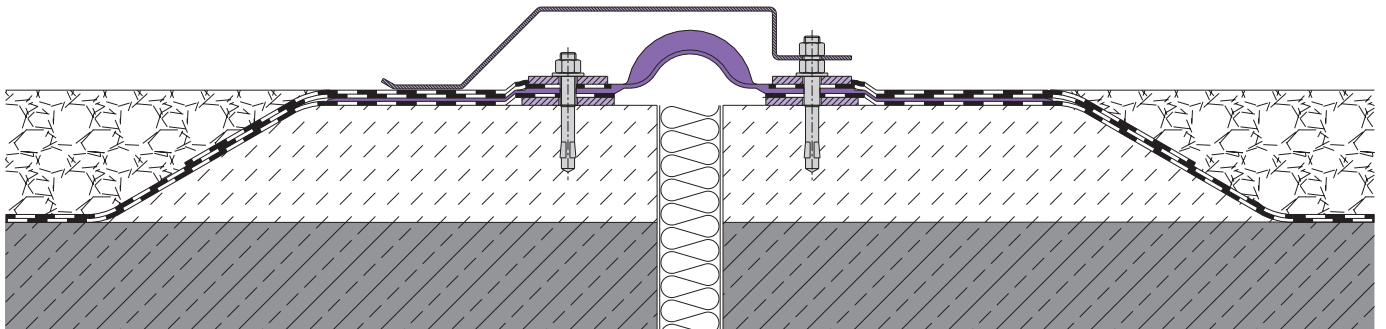

WFB 550/F

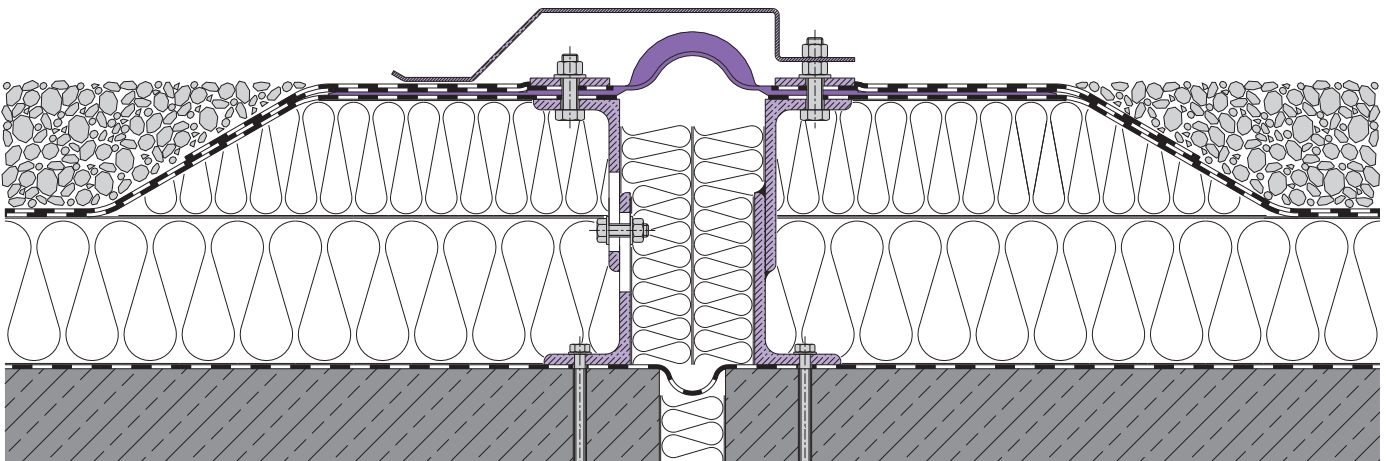

WFB 550/FWD

Installation Examples WFB 550

Flat roofs – Method 2: Bonding

The following illustrated installation examples have to be in accordance with their structural conditions individually reviewed and determined for each case.

They do not show the functional layers.
These have to be determined by the on-site situation.

N.B. these drawings are not to scale.

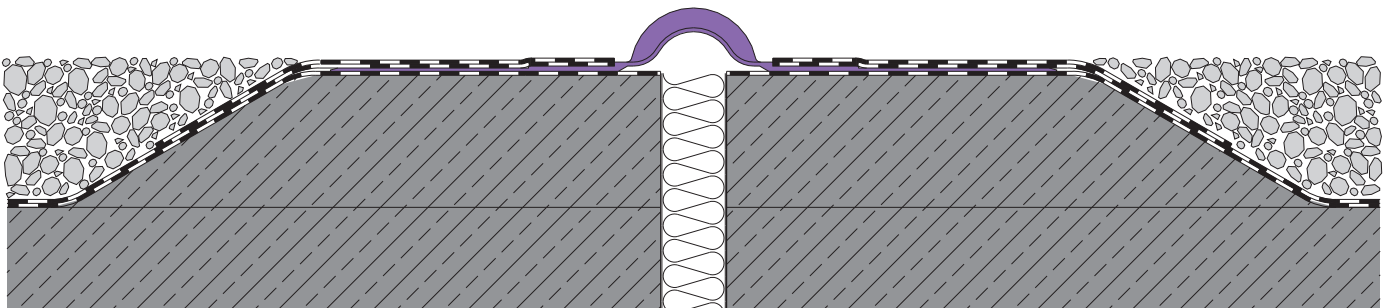

WFB 550/E

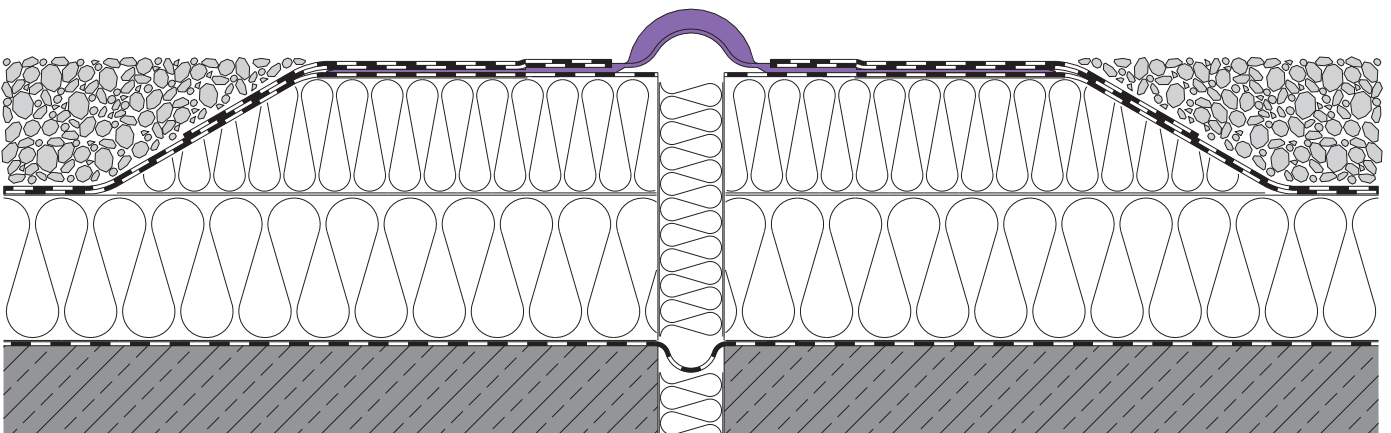

WFB 550/EWD

Installation Examples WFB 550 Flat roofs – Corner Version Flange connection DIN 18195 part 9

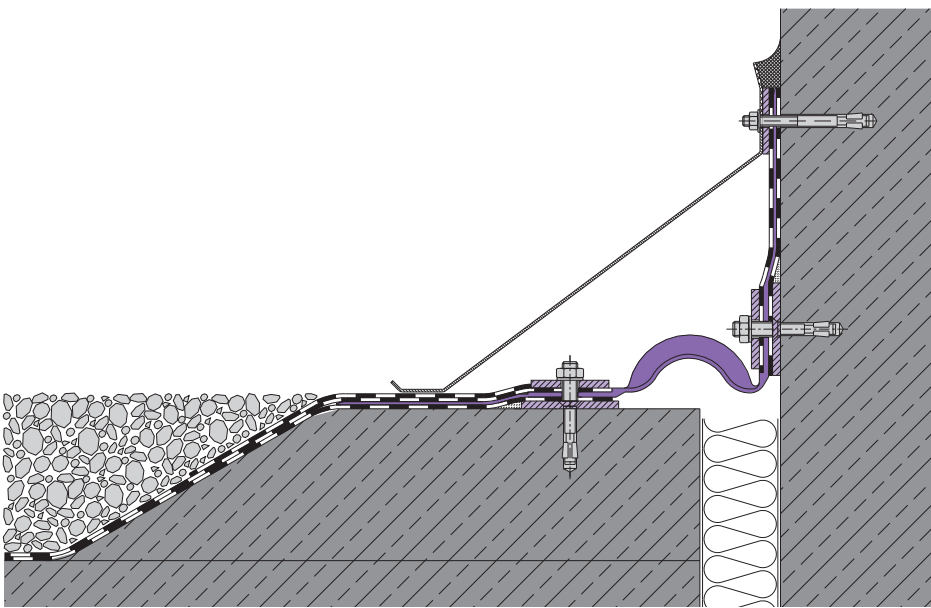

WFB 550/FE

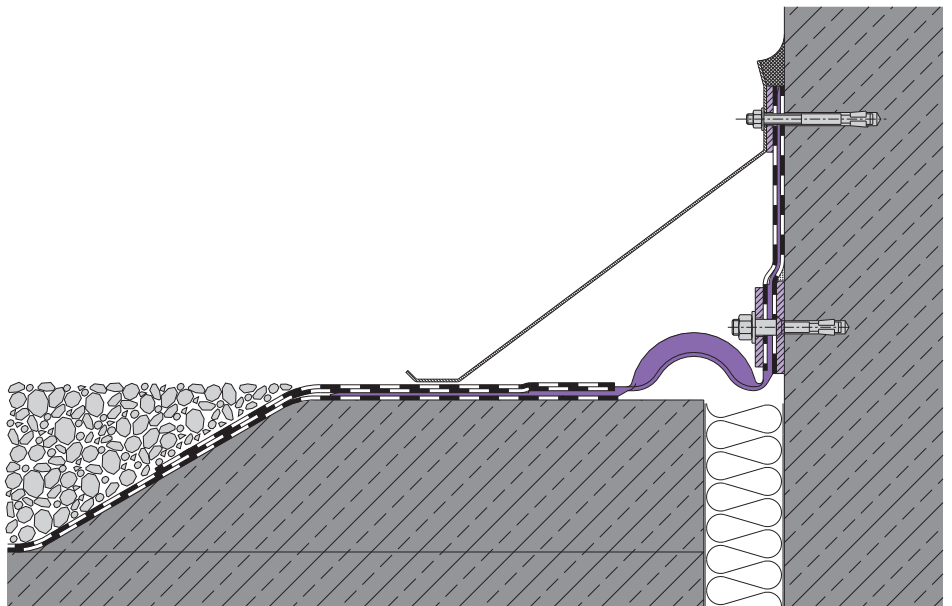

WFB 550/EE

Installation Examples WFB 550 Covered areas

If the corrugated jointing system is used in yards underneath paved floors and/or grassed areas over underground car parks, the corrugations have to be covered to ensure the movement capacity of the system.

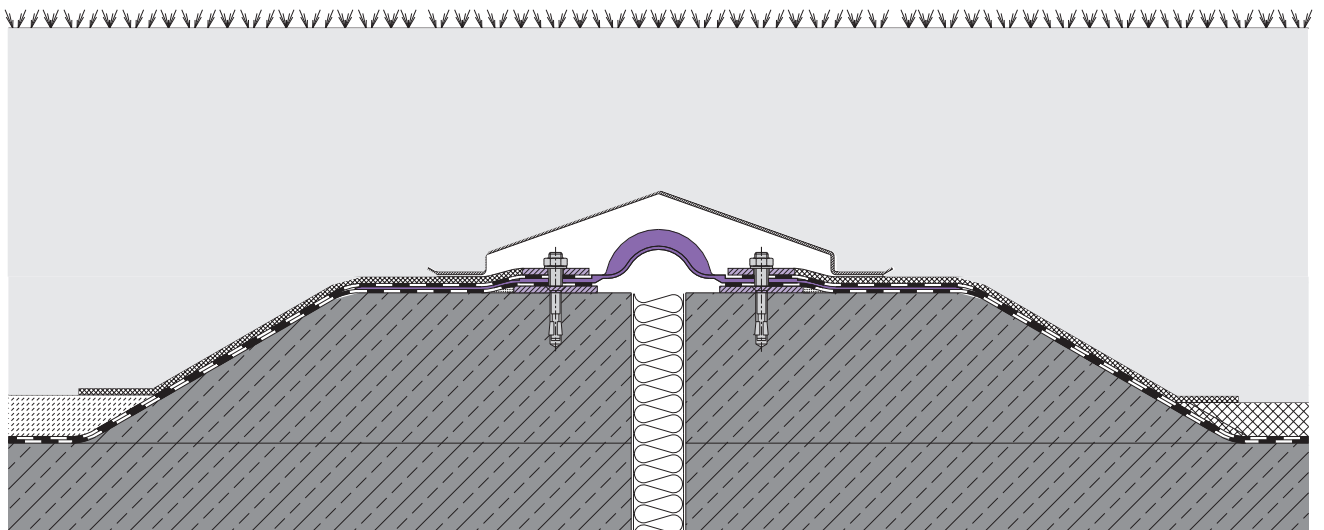
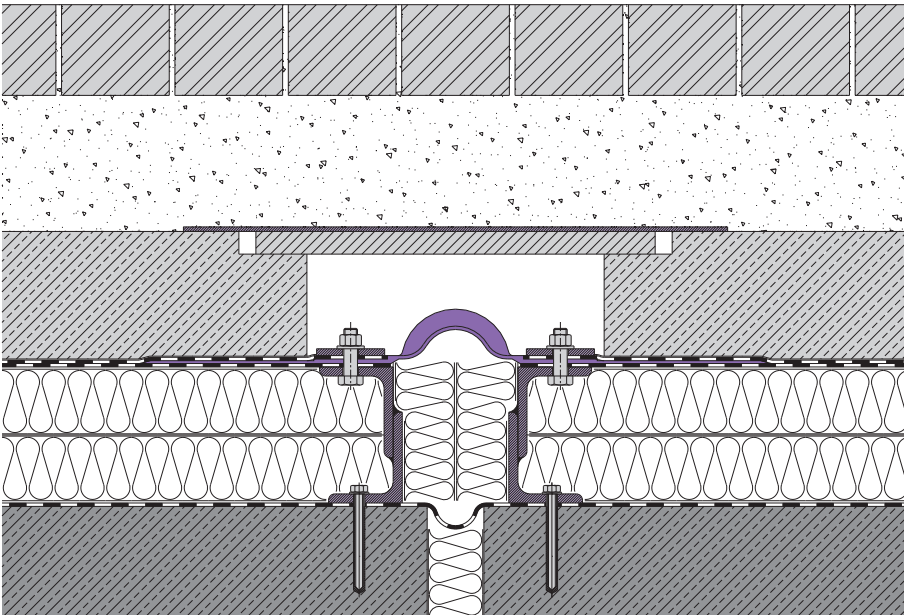

Installation Examples WFB 550

Covered areas

Corner Versions

If the corrugated jointing system is used in yards underneath paved floors and/or grassed areas over underground car parks, the corrugations have to be covered to ensure the movement capacity of the system.

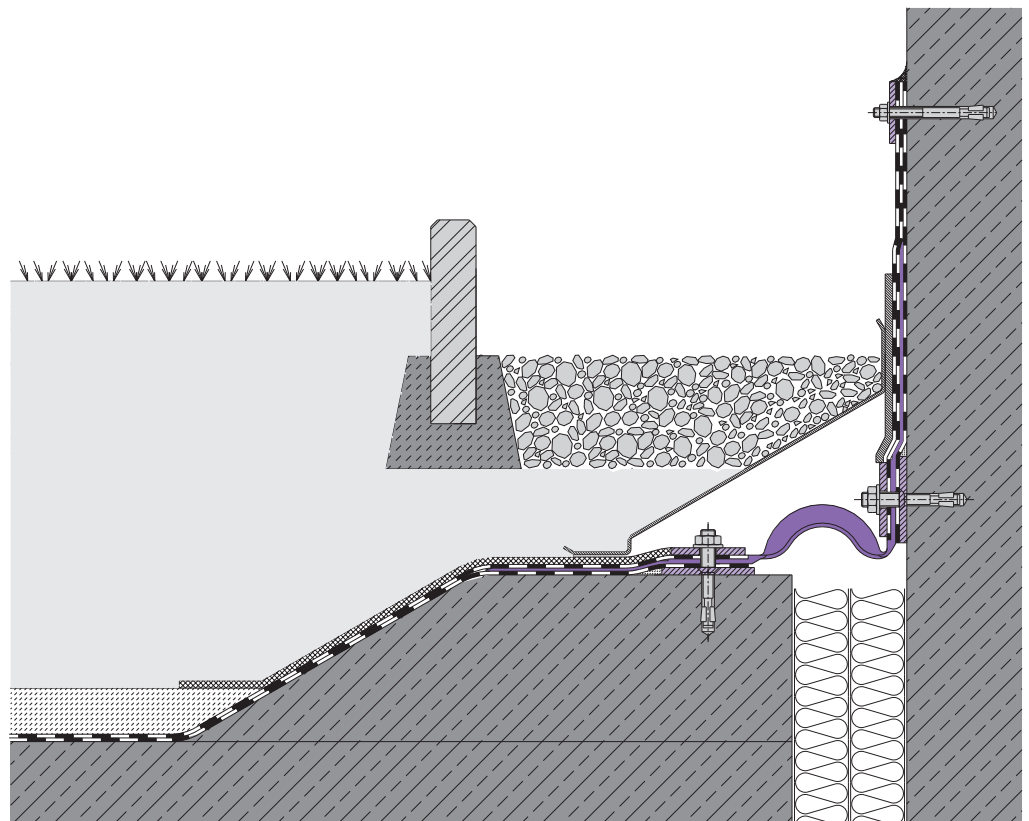

Installation Examples WFB 550

Loose- and fixed-flange-construction Arrangement

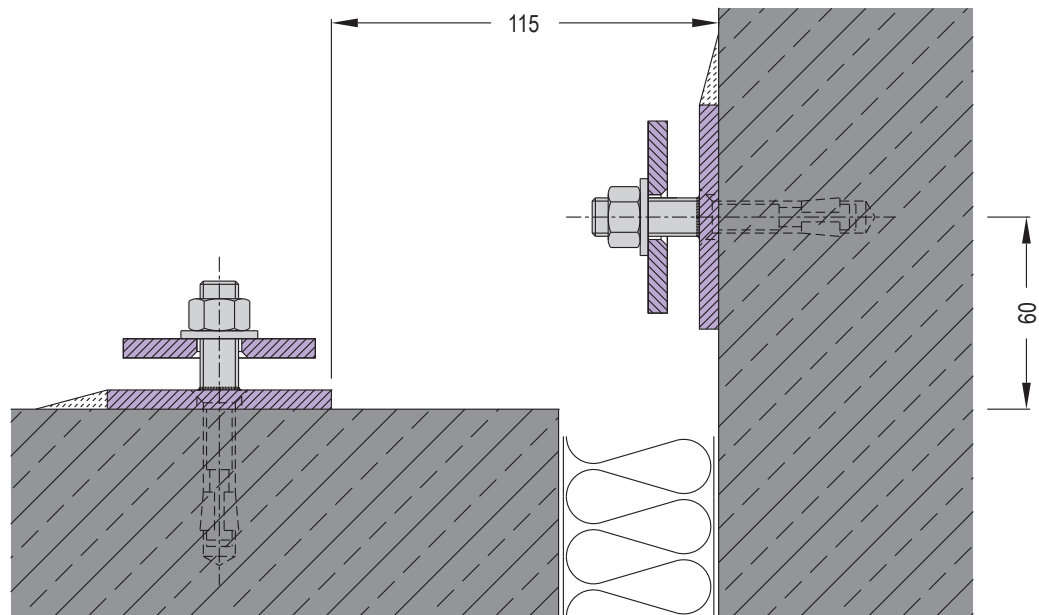
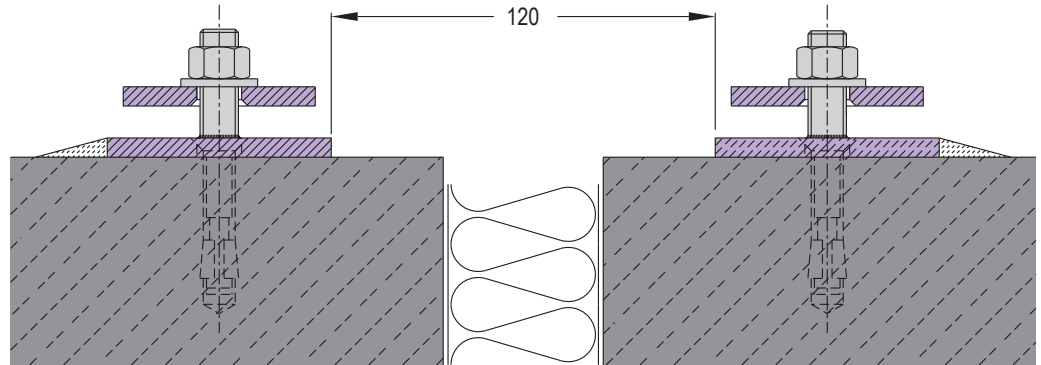

Standard Measures

Content from
DIN 18195 part 9

Loose-flange

Width: ≥ 60
Thickness: ≥ 6

Fixed-flange

Width: ≥ 70
Thickness: ≥ 6

Screws/Bolts

Diameter: ≥ 12
Distance between each: 75–150
Distance from each end: ≤ 75

Intersections WFB 550 / MP Examples

AU 90°

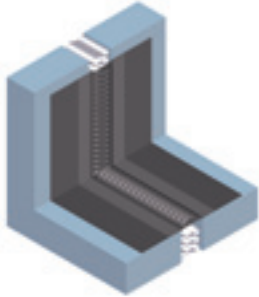

AU - R X°

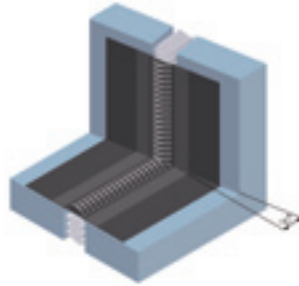

AU - L X°

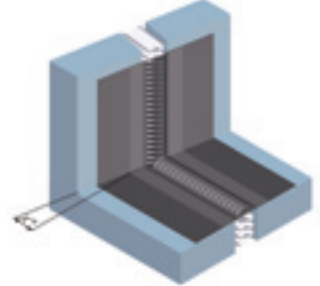

AU - I X°

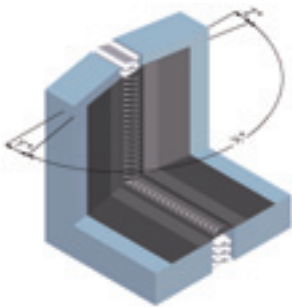

AU - A X°

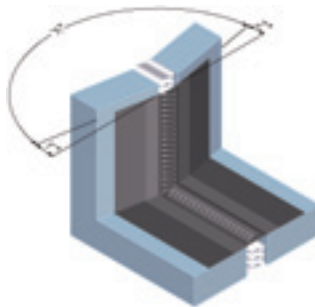

AU - E - R 90°

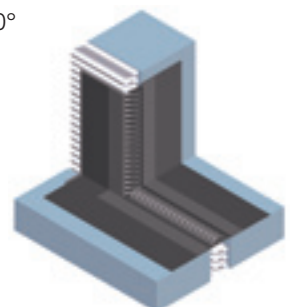

AU - E - L 90°

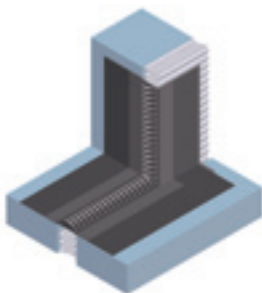

AU - W - R 90°

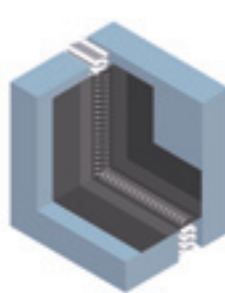

AU - W - L 90°

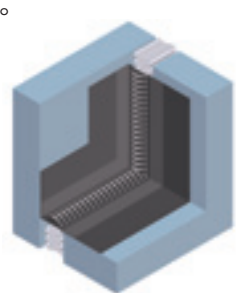

AU - W - R X°

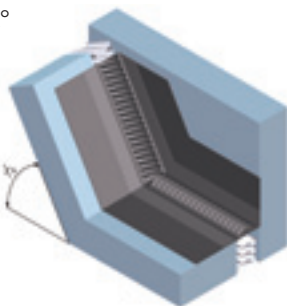

AU - W - L X°

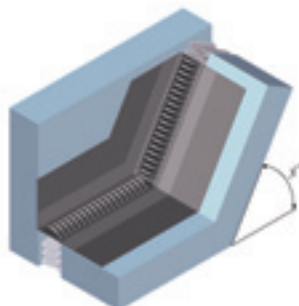

AU - W - S - R X°

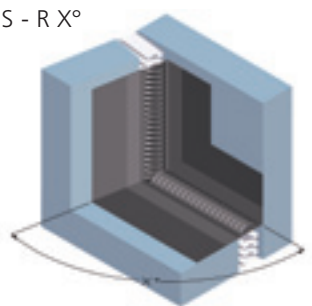

AU - W - S - L X°

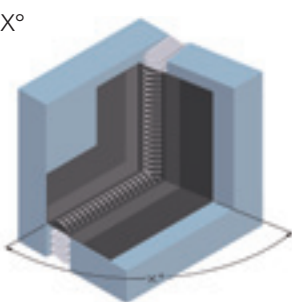

AB - 90°

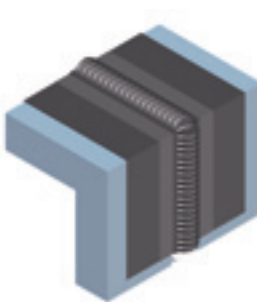

AB - R X°

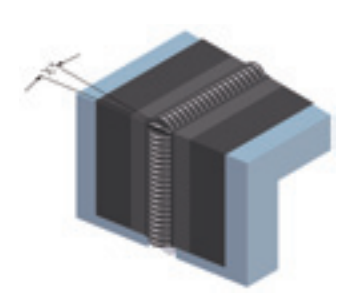

Intersections WFB 550 / MP Examples

AB - L X°

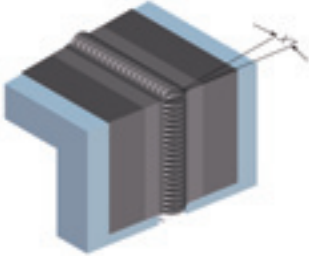

AB - I X°

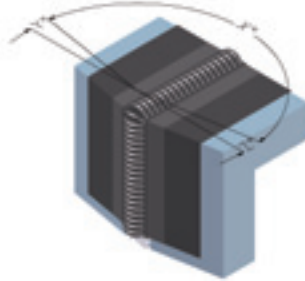

AB - A X°

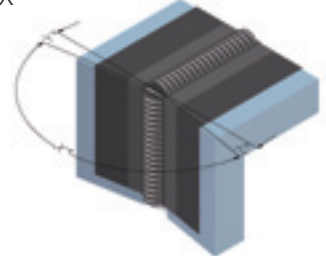

AB - E - R 90°

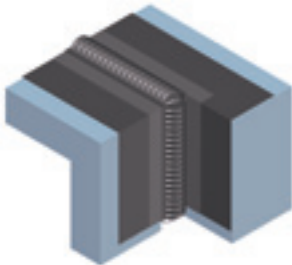

AB - E - L 90°

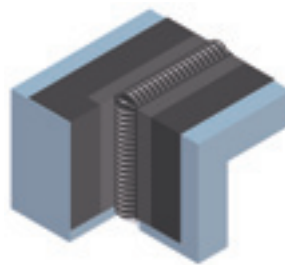

AB - W - R 90°

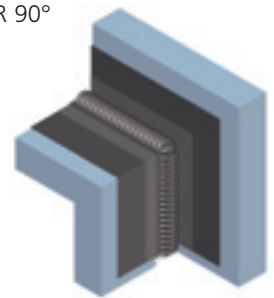

AB - W - L 90°

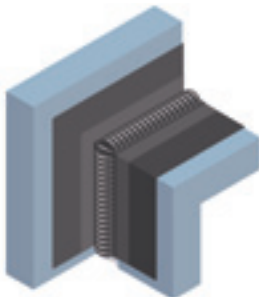

AB - W - R X°

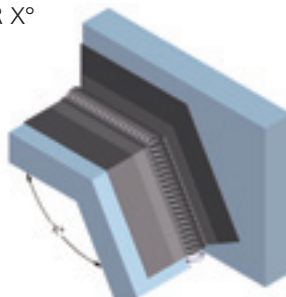

AB - W - L X°

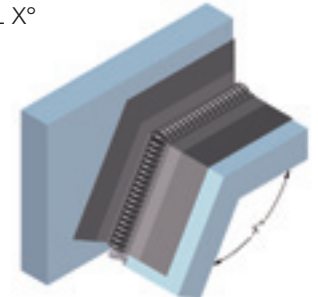

AB - W - S - R X°

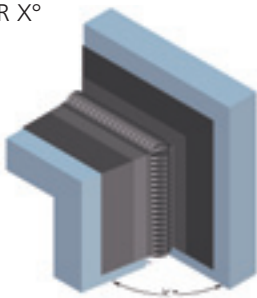

AB - W - S - L X°

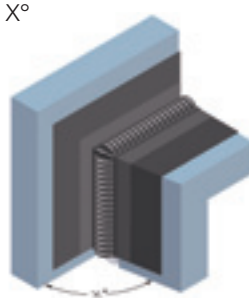

AB - WE - R 90°



AB - WE - L 90°



BW - R 90°

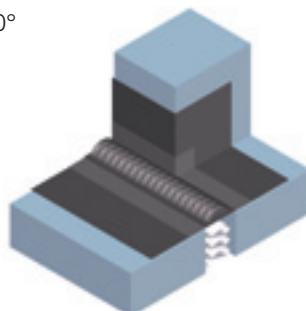

BW - L 90°

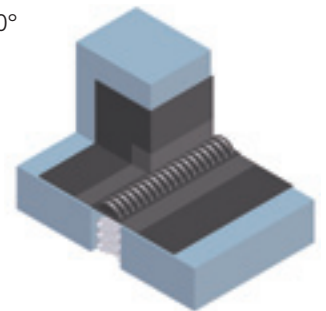

Intersections WFB 550 / MP Examples

BW - R X°

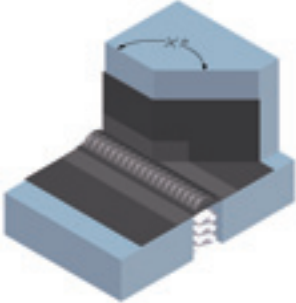

BW - L X°

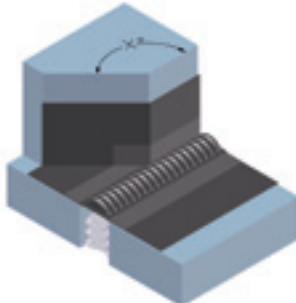

WF 90°

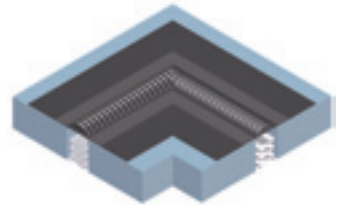

WF X°

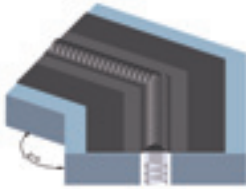

WF - R 90°

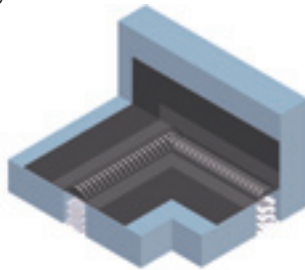

WF - L 90°

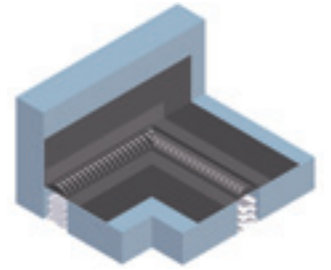

WF - A 90°

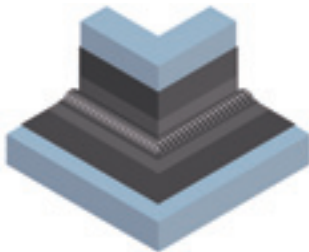

WF - I 90°

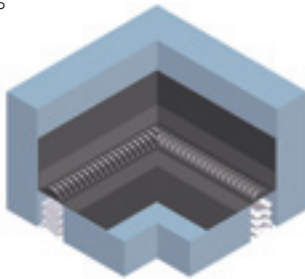

WF - A X°

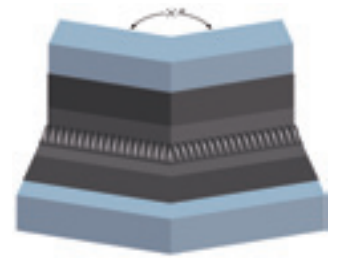

WF - I X°

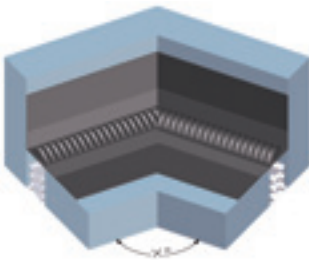

WF - W - R 90°

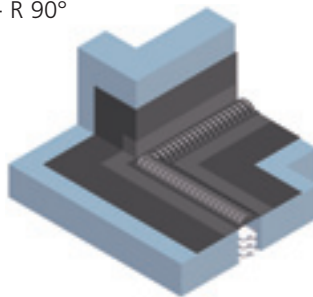

WF - W - L 90°

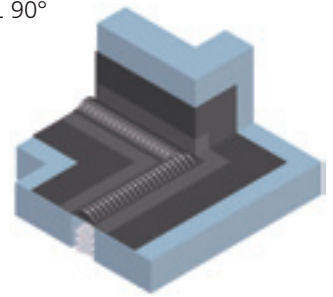

WF - AU - R 90°

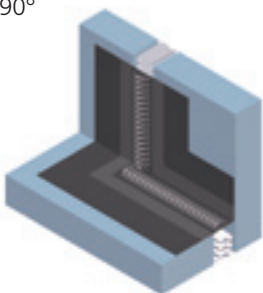

WF - AU - L 90°

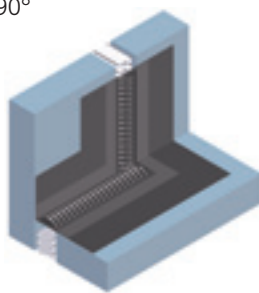

WF - AU - R X°

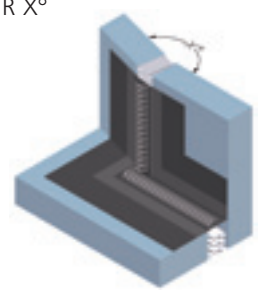

Intersections WFB 550 / MP Examples

WF - AU - L X°

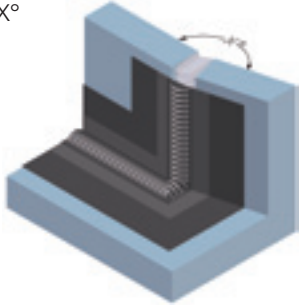

WF - AU - E - R 90°

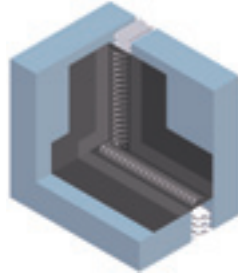

WF - AU - E - L 90°

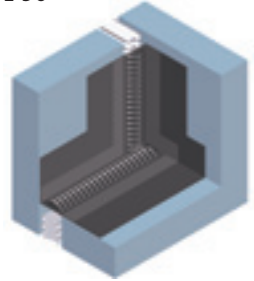

WF - AB - E - R 90°

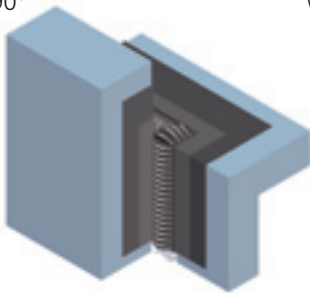

WF - AB - E - L 90°

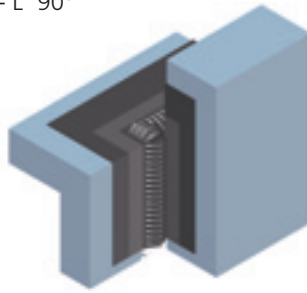

TF 90°

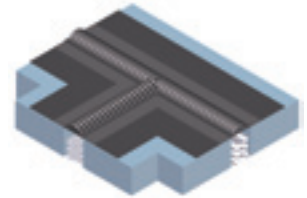

TF - W 90°

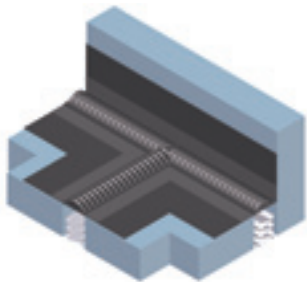

TF - W1 90°

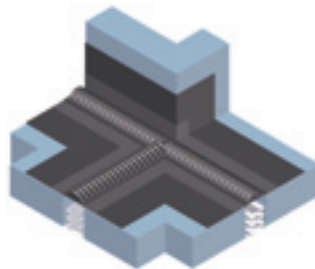

TF - W2 90°

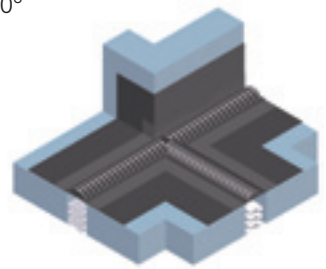

TF - W3 90°

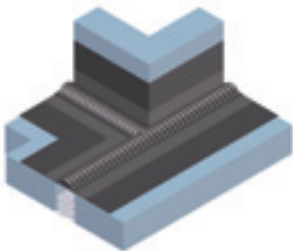

TF - W4 90°

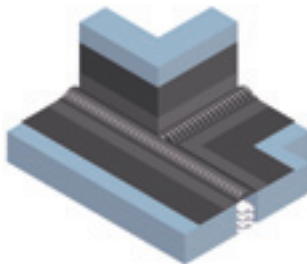

TF - AU 90°

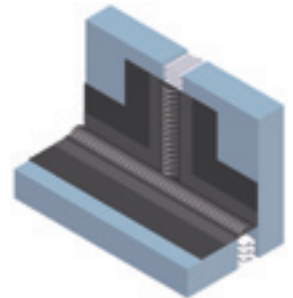

TF - AU - R 90°

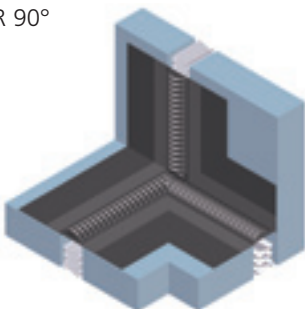

TF - AU - L 90°

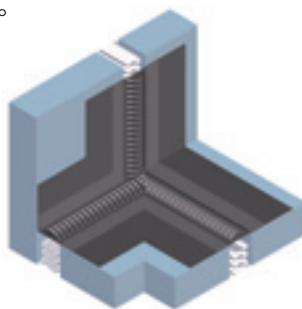

TF - AU - E - R 90°

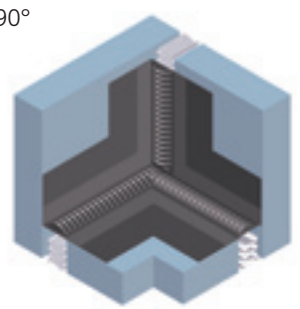

Intersections WFB 550 / MP Examples

TF - AU - E - L 90°

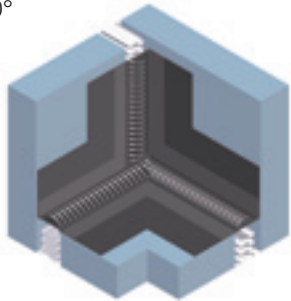

TF - AB - R 90°

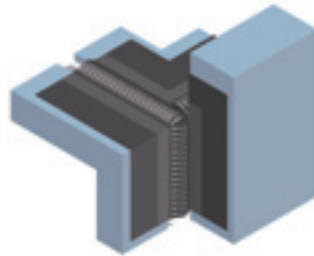

TF - AB - E - L 90°

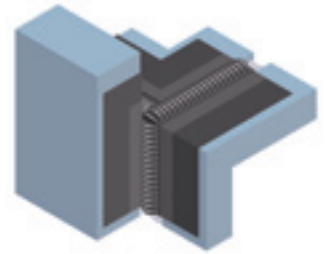

KF 90°



KF - W 90°

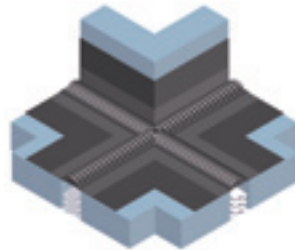

KF - AU 90°

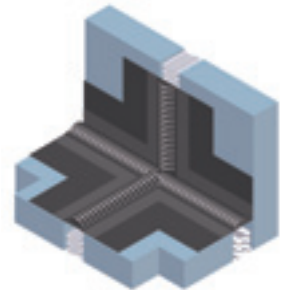

Round column connection

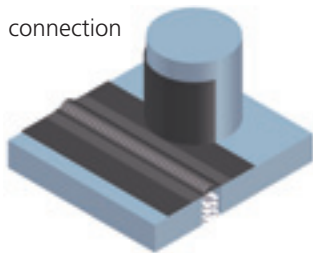

Collar

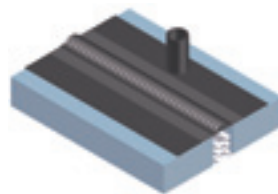

WFB - DK

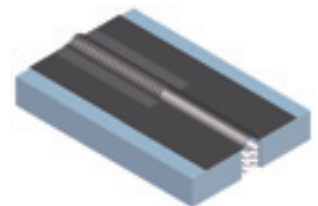

DKEA

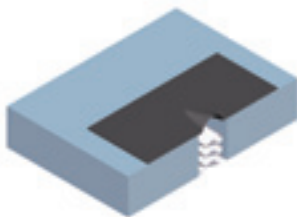

DKEA - W - R 90°



DKEA - W - L 90°

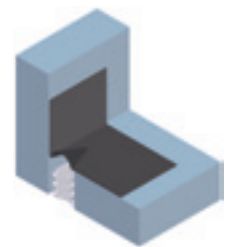

If a hollow moulding is built, vertical inside corners can easily be installed without the use of prefabricated upstand (AU).

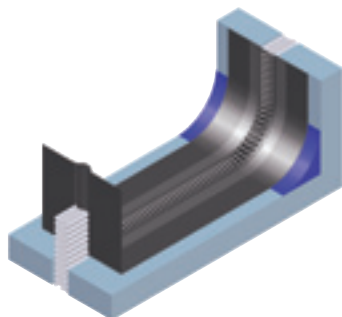

If the edges are chamfered, vertical outside corners can easily be installed without the use of prefabricated downstand (AB).

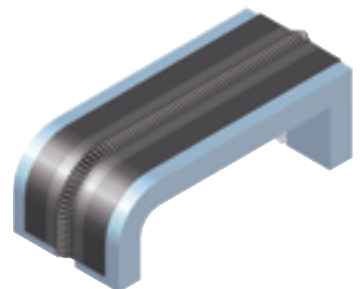

Systems WFB 550 / MP Examples

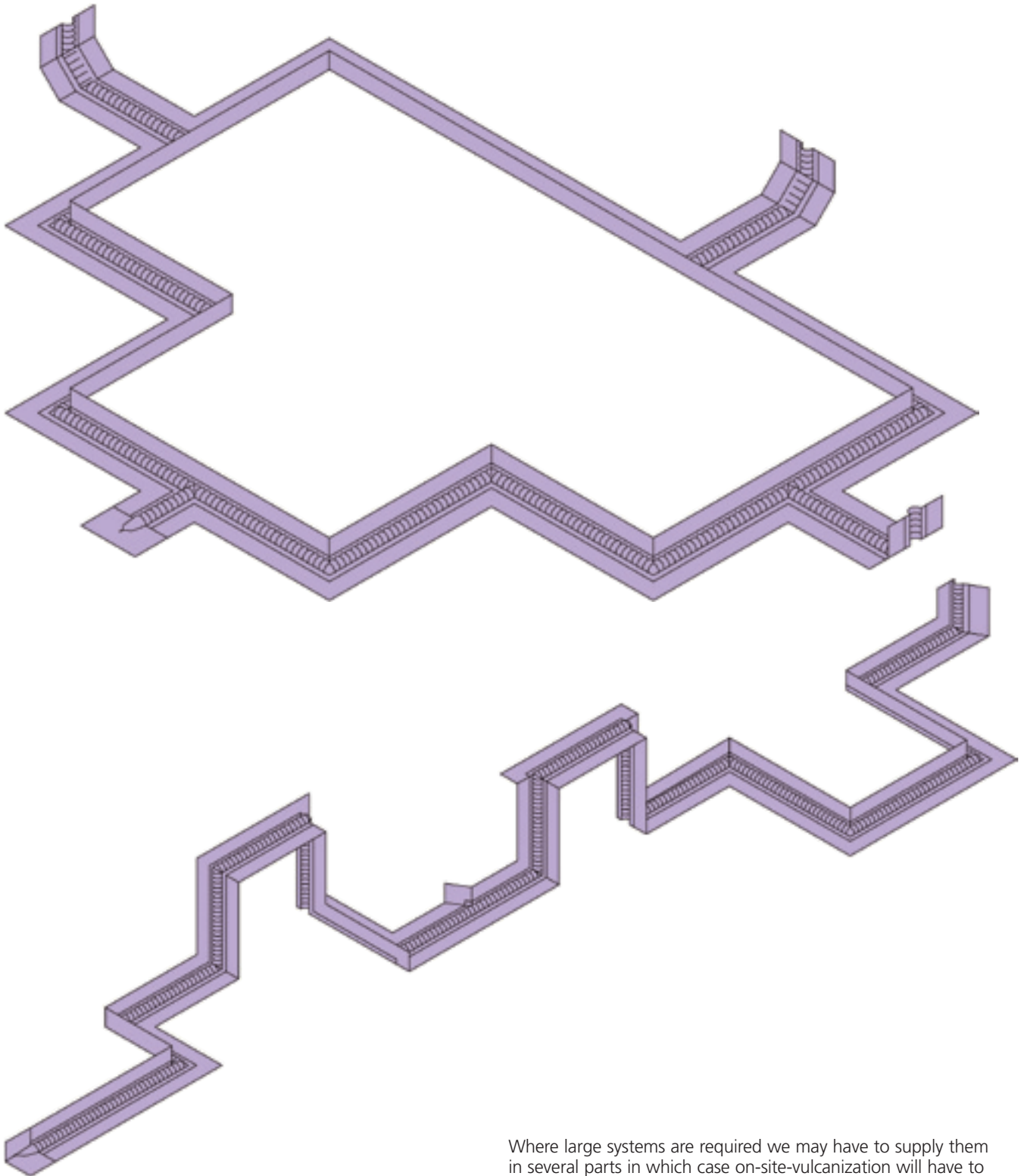

Where large systems are required we may have to supply them in several parts in which case on-site-vulcanization will have to be done.

Examples WFB 550

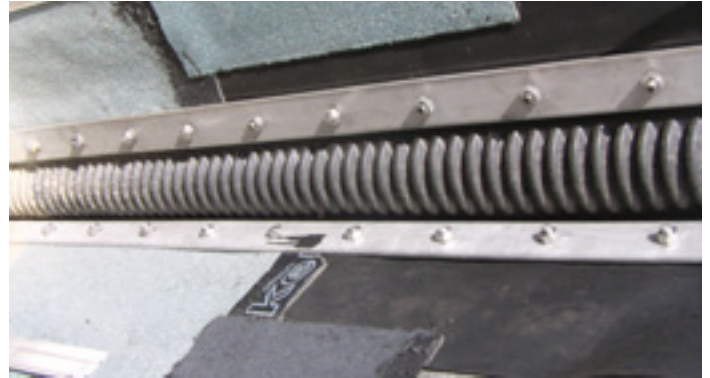
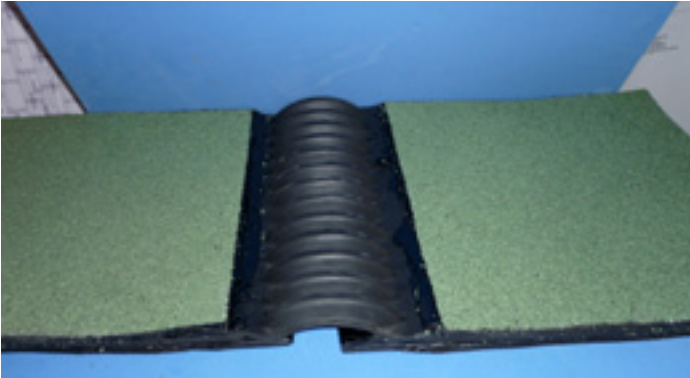

Examples WFB 550

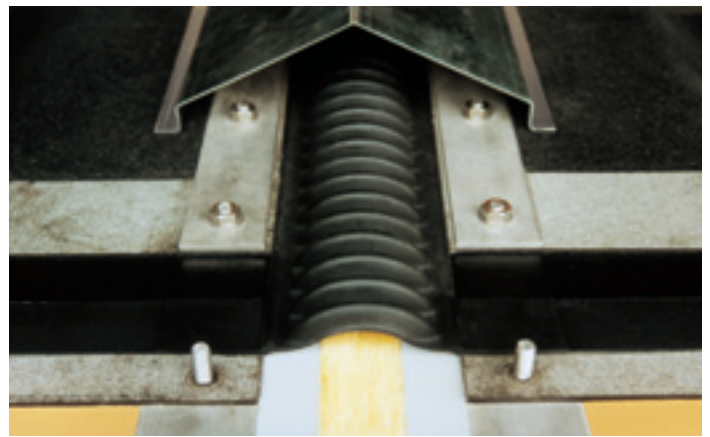

Moulded intersections

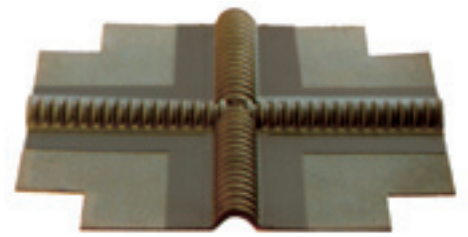

Sealing strip for sealing against non-pressurized water (DIN 18195)

DK 550

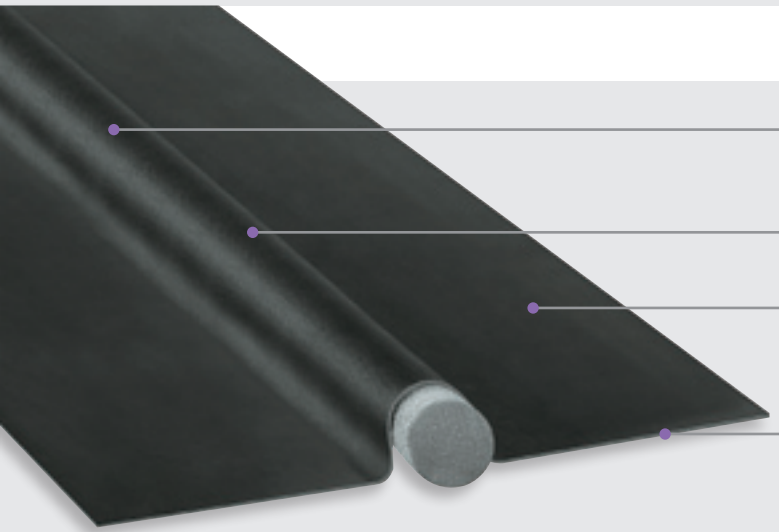

Flexible Loop Formation

for reliable sealing of different joint width

Large horizontal and vertical movement capacity

Structural connection flanges,

for safe adhesion in hot bitumen between bituminous roof layers

Intersections and connections

in connection with WFB 550 possible

Profile	Thickness [mm]	Total width b_t [mm]	Joint width max. b_f max [mm]	Movement capacity in 3-dimensions [mm]
DK 550	2	550	120	± 25

Please ask for our separate installation instructions and technical advice. We ensure a perfect fit by taking measurement on site (complete systems including all intersections, transitions and connections will be done in our factory). Where large systems are required we may have to supply them in several parts in which case on-site-vulcanisation will have to be done. All necessary intersection will be done with the corrugated jointing system WFB 550 and vulcanized to the DK 550.

Material: Polychloroprene, resistant to hot bitumen

Standard colour: black

Production length: 15 m

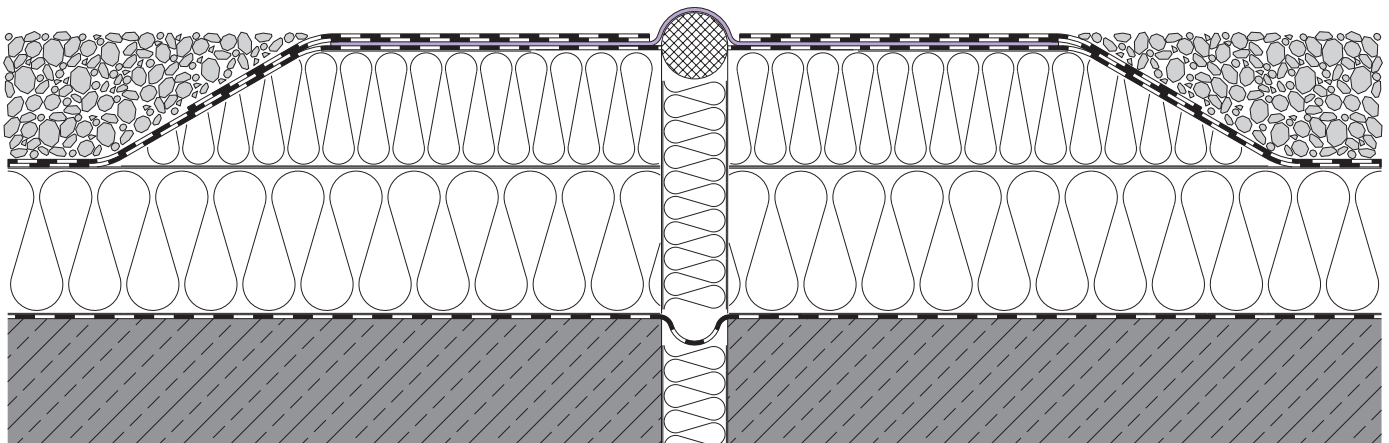

It is much important that the size of the loop which has to be formed on site is in accordance with the expected movement. The loop should be supported by a baker rod.

MIGUA. Market leader in Europe for more than 50 years.

MIGUA is completely focused on expansion joint systems. Leading architects, designers and general contractors specify our products for national and international projects. We will gladly provide you with a list of references, on request.

MIGUA expansion joint systems are used from Abu Dhabi to Zurich providing protection, functionality and architectural excellence on a permanent basis.

They are used in many different building types, e.g. shopping malls, airports, exhibition halls, hospitals, industrial plants, storage facilities, car parks and pedestrian bridges. It is our passion to be innovative, to supply perfect quality and to develop solutions according to customer requirements.



MIGUA Headquarters in Wuelfrath

Technology. Innovative from experience.

Competence does not appear by chance. More than 10 million metres of MIGUA movement joint systems have, over decades, been installed worldwide to the satisfaction of architects, designers, builders and owners. We are leaders in technological development in Europe as witnessed by numerous patents and test certificates.

MIGUA engineers are, on an ongoing basis, designing and developing new profiles with enhanced characteristics which lead to time and cost saving installations.

Through the use of special materials safety features are improved and stringent performance tests are conducted on all new products.

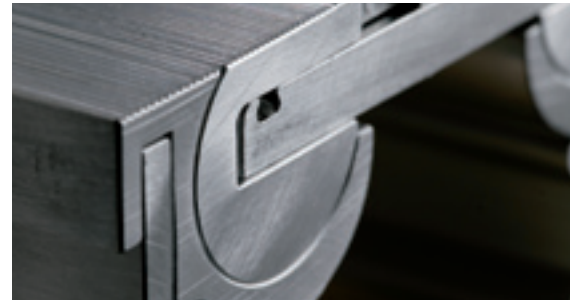

Quality. Made in Germany.

MIGUA products combine optimum solutions with excellence in design, high quality materials and safety features which are supported by our standard warranties. Quality makes the pre-condition for product safety. That is why MIGUA develop and manufacture in Germany. Only products on the highest standard achieve the necessary durability and allow required warranties.

Due to this reason MIGUA is able to offer such warranties.

Beyond the technical quality of our products the main target of the MIGUA quality management is the utmost satisfaction of our customers. Each operation and work step is described and will be recorded. From the first idea through research and development up to successful market launch. Just this makes MIGUA successful.



Solutions. Which work.

By ensuring the technical quality of our products MIGUA can attain its primary goal of complete customer satisfaction. We understand the expectations of our customers, and how to exceed them.

This requires a strong commitment for special requests and solutions. MIGUA is prepared for it – from the beginning. We are always available for your questions or giving advice to find the solution our customers need. Our products are supported by a national network of technical experts, close cooperation with our world-wide partners and an experienced international export team.

MIGUA offers the perfect solution for your project.

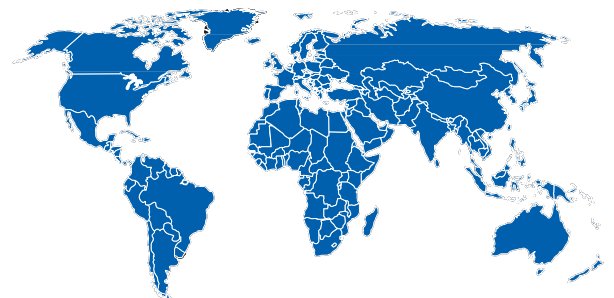

MIGUA offers a comprehensive product portfolio of expansion joint covers and systems with outstanding features.

Increasing architectural requirements as well as new construction materials and processes demand optimized expansion joint systems. For this reason, MIGUA is your experienced partner since we offer more than 600 different profiles for a wide range of applications.

Our product range covers 5 application orientated product groups as detailed below. In addition to standard profiles our R&D engineers provide highly sophisticated solutions for special or non-standard applications.

MIGUA provides solutions for extraordinary challenges.

MIGUTEC

Expansion joint profiles

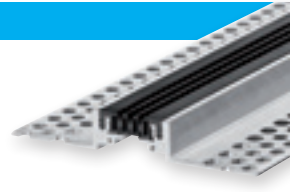

MIGUTRANS

Heavy duty expansion joint systems

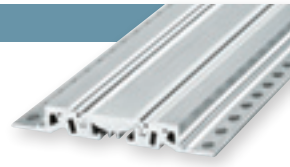

MIGUTAN

Watertight expansion joint systems for traffic



MIGUPREN

Watertight expansion joint systems for roofs

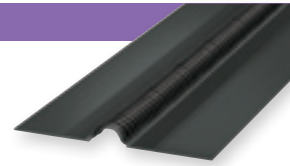

MIGUMAX

Earthquake resistant expansion joint systems



MIGUA[®]

FUGENSYSTEME GMBH & CO. KG

Postal address:

PO Box 1260 · 42479 Wuelfrath

Headquarters:

Dieselstr. 20 · 42489 Wuelfrath

Phone +49 2058 774-0

Fax +49 2058 774-48

info@migua.de

www.migua.com